

Steam Turbines

FINCANTIERI
The sea ahead

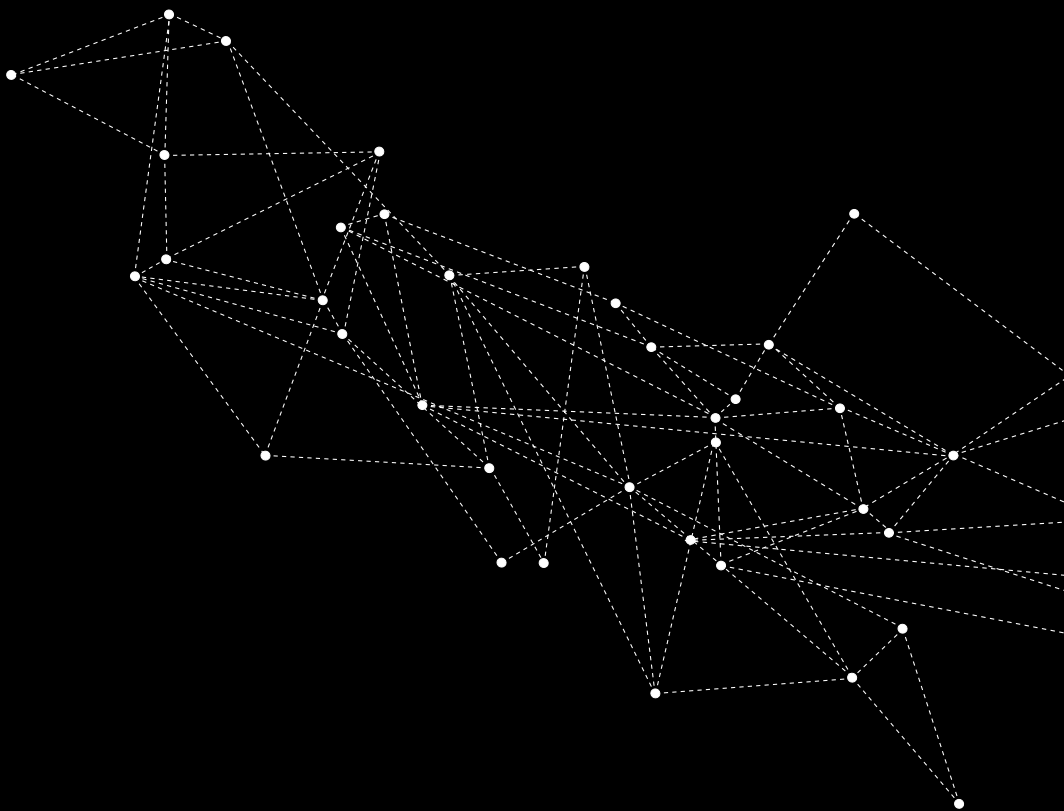



Steam Turbines

— For over ninety years Fincantieri has designed and manufactured steam turbines, on modular construction systems to optimise the efficiency for specific project requirements. Fincantieri steam turbines reliability and design flexibility have allowed their application both for industrial purposes either power generation or mechanical drive (power plants; oil refineries; petrochemical plants; waste treatment plants; sugar mills; paper mills) and in the marine field (ship propulsion and turbo-generators). Design and production follow extensive and continuous research activity, resulting in high efficiency, reliability and quality of the final products. Fincantieri steam turbine production range includes multi-stage/single and multi-valve backpressure or condensing types with or without controlled/uncontrolled steam extractions.

Machines are available for power output up to 50,000 kW with steam inlet conditions of up to 125 bar/540° C and rotational speeds from 3,000 rpm to 13,000 rpm.



Type	F Series	TVR/THR	MS-VS	36	45	50	56	60	70	80	100
CONDENSING											
BACKPRESSURE											
CONTROLLED EXTRACTION											
MULTI STAGE											
MULTI VALVE											
SINGLE STAGE											
SINGLE VALVE											
INDICATIVE POWER [kW]	1,500	300/4,400	4,000	9,000	8,000	16,000	25,000	21,000	26,000	35,000	50,000
TYPICAL SPEED [RPM]	5,000/8,000	6,700/18,000	11,000	13,000	11,000	8,200	9,000	7,200	6,300	5,200	4,200

TURBINE TYPE

00 = first stage medium diameter in cm
 C = condensing
 B = backpressure
 E = controlled extraction

Example:

36 CE is a condensing type with controlled extraction, the first stage medium blade diameter is 36 cm.

QUALITY assurance

- The Quality System implemented for the design and manufacturing of the Fincantieri Mechanical Products is certified with reference to ISO 9001, standard.
- The Environmental Management System of Fincantieri Mechanical Products manufacturing site is certified with reference to ISO 14001
- The Occupational Health and Safety Management System of Fincantieri Mechanical Products manufacturing site is certified with reference to OHSAS 18001.

Condensing Turbines

— Condensing turbines steam path is diaphragms and disks type. The rotor disks are solid with the shaft in order to maximise strength and reliability. The casings are cast steel made, horizontally splitted. The exhaust side can be cast steel or steel fabricated, either upward or downward oriented. The rotor supporting system is “centreline”, assuring a good alignment with the different temperature distributions corresponding to the various loads. Fincantieri also provides condensing steam turbines with controlled extraction.

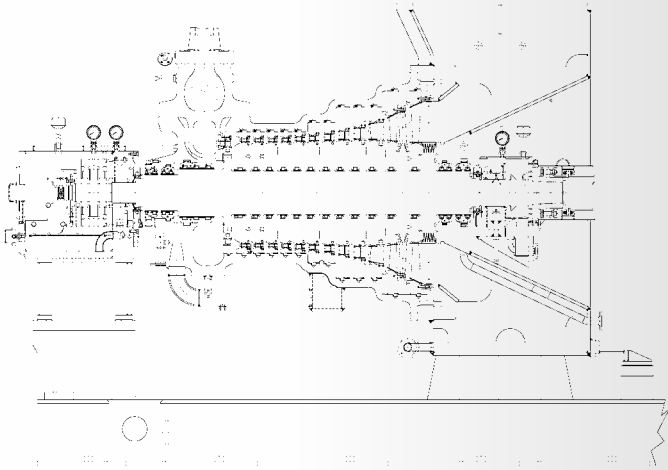

Backpressure Turbines

— Backpressure steam turbines are installed in all industrial plants which use the entire exhaust steam flow for heat recovery. Fincantieri backpressure steam turbines are with a horizontally split casing. The construction is of diaphragm and disk type. The rotor disks are solid with the shaft in order to maximise strength and reliability. The casings are in alloyed steel and the exhaust can be either upward or downward. Fincantieri also provides backpressure steam turbines with controlled extraction.

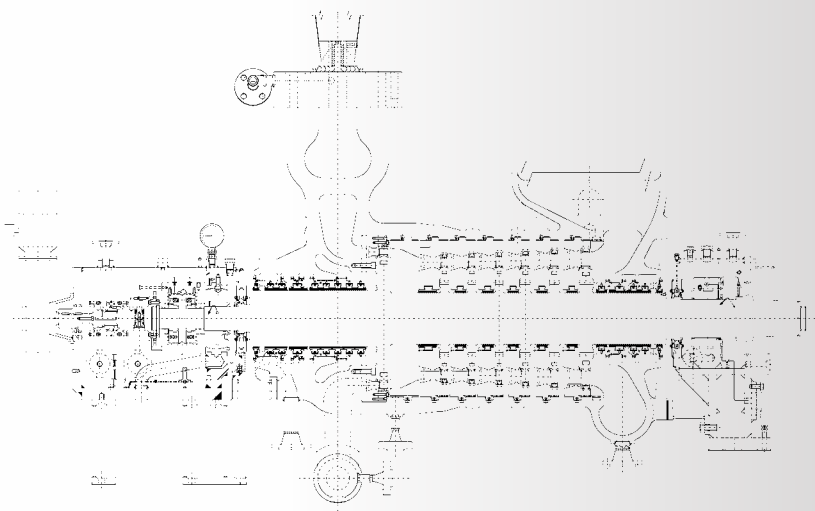
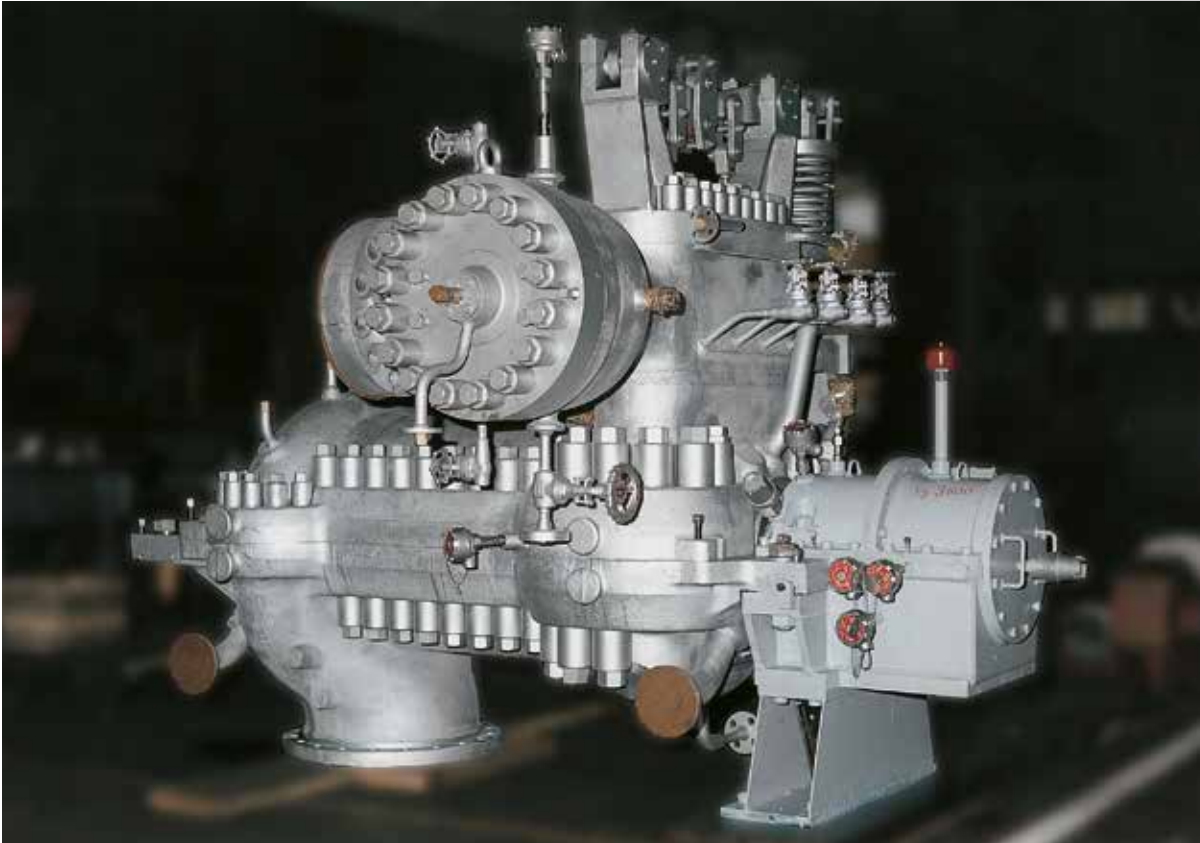

Controlled Extraction Type

— For all industrial applications - requiring the supply of part of steam flow to the process with constant pressure - Fincantieri provides turbines with controlled extraction. The intermediate sections of the casing are replaced by extraction modules equipped with valves and actuators for extraction pressure control.

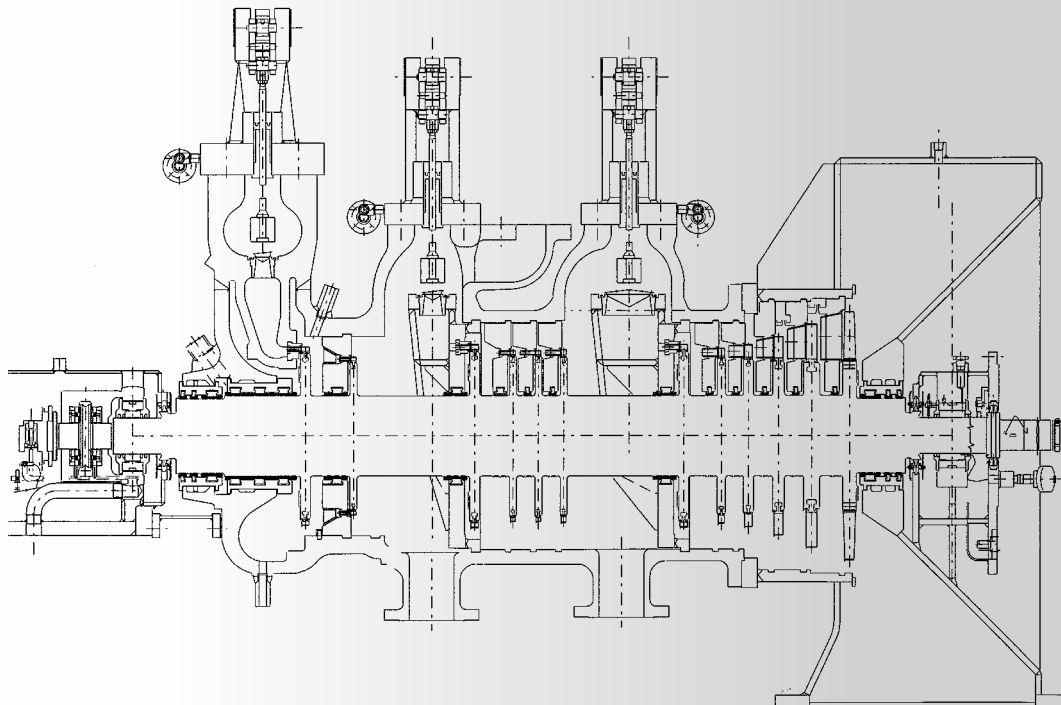
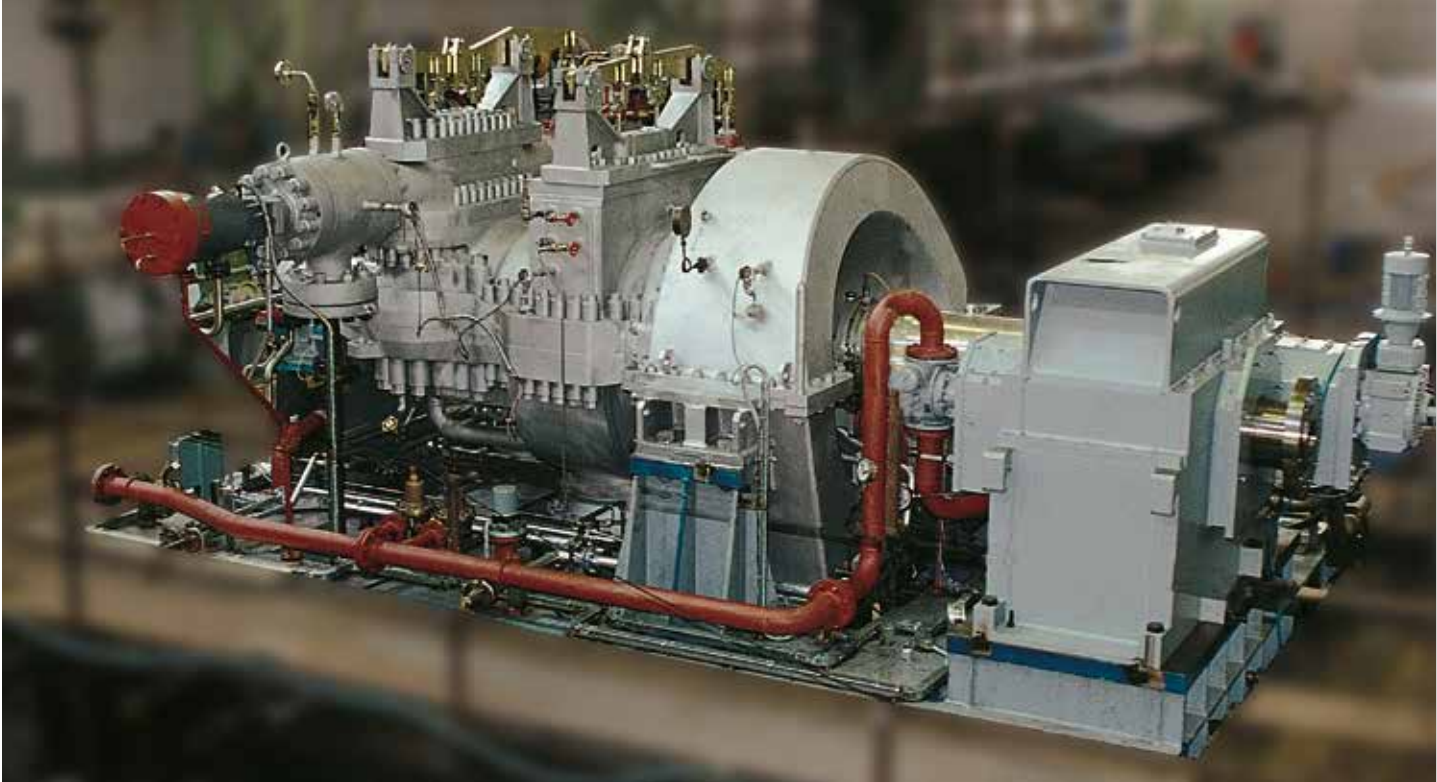

Boiler Feed-Water Pump Turbines

— For the specific service of boiler feed water pump drive in thermal power plants, Fincantieri has developed steam turbines with a dual admission and internal changeover for HP/LP steam in its range of production. This steam turbine can also drive a second pump (booster) by an additional shaft end.

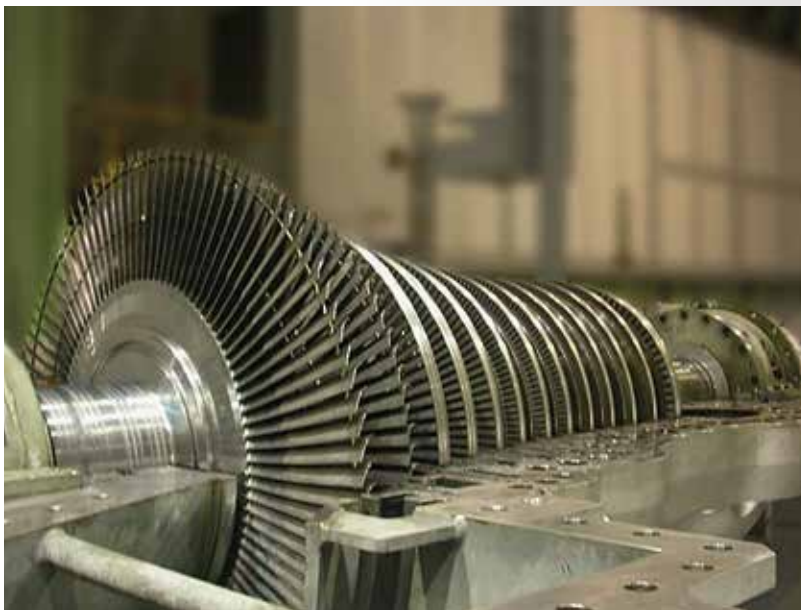
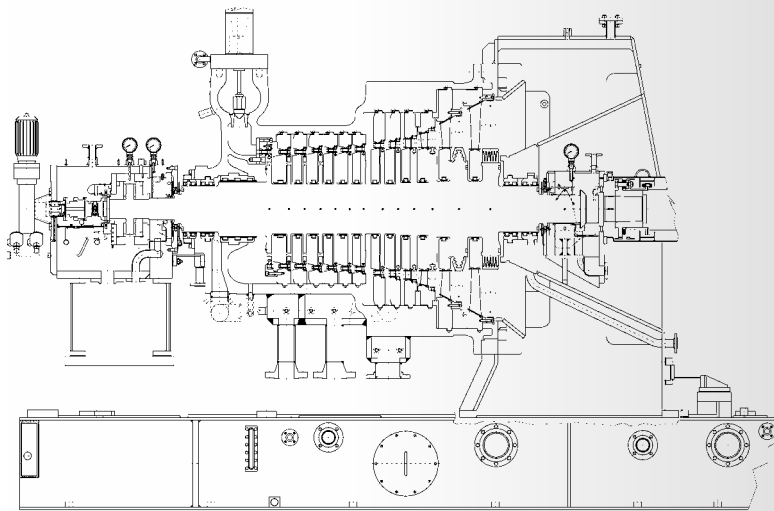

_ HP Valve for Separate Steam Admission

Turn Key Solutions

— Fincantieri is able to propose and realize turn-key solutions concerning the steam turbine island.

In particular, Fincantieri can offer:

- mechanical BOP (design, material supply and installation);
- electrical BOP (design, material supply and installation, including new MV cubicles and revamping of MV plant section);
- cooling part of the steam plant (WAC condenser, ACC condenser with ancillaries, cooling towers and relevant BOP);
- HP and LP District Heaters and accessories;
- enclosure for outdoor installation complete with fire-fighting system and accessories;
- steam turbine generator concrete table design.

Fincantieri can provide complete steam turbine generator erection and commissioning, with responsibility till the delivery to the end user.

— Many customers have already confirmed their trust in Fincantieri's experience and reliability. Fincantieri can count on different references in Europe and Northern Africa for industrial and Oil&Gas installations.

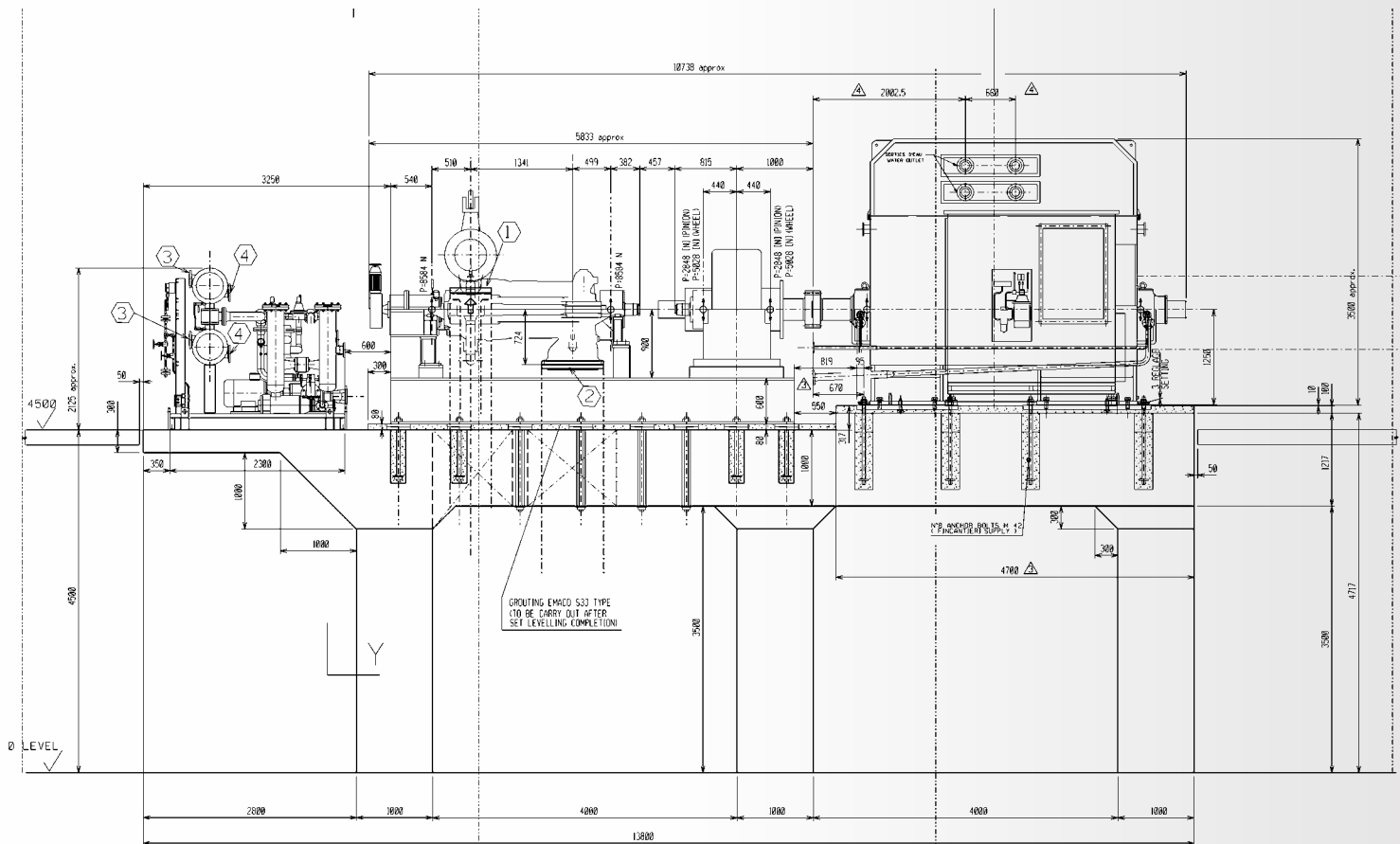
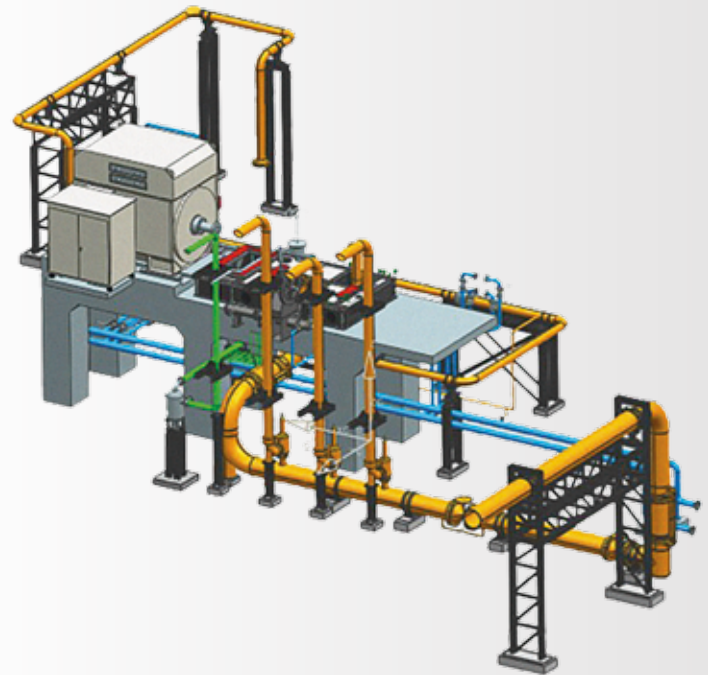

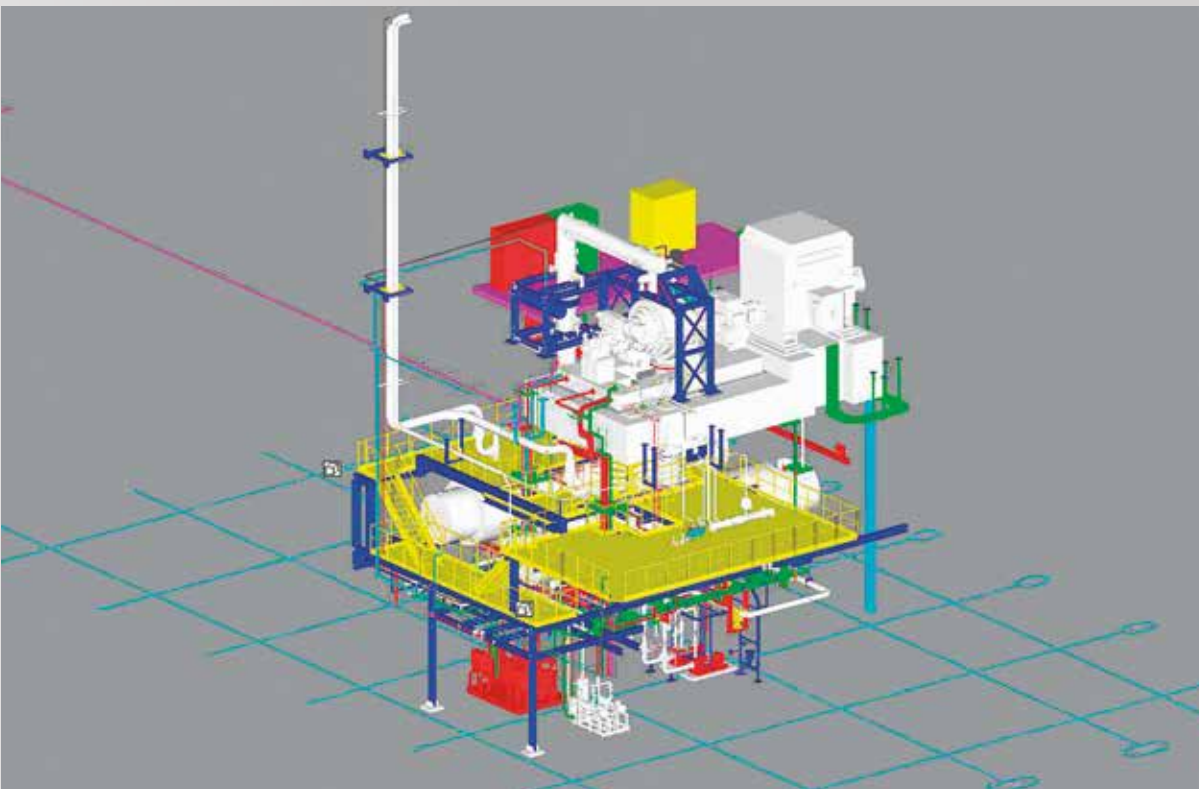

CHP - District Heating Applications



CHP - Combined Heat and Power Applications for District Heating Purposes

— Fincantieri steam turbine line suitable for production of electrical power and hot water for District Heating purposes. The District Heating net is fed directly by the exhaust steam thanks to turbine exhaust sections suitable to be operated at pressures approximately at atmospheric pressure. Hot water is produced directly in the District Heating Condensers in single or double arrangements. Such CHP solution is widely used in the Nordic countries where cold temperatures occurs in any period of the year. Fincantieri provides turn key solutions including DH exchangers and interconnecting piping.

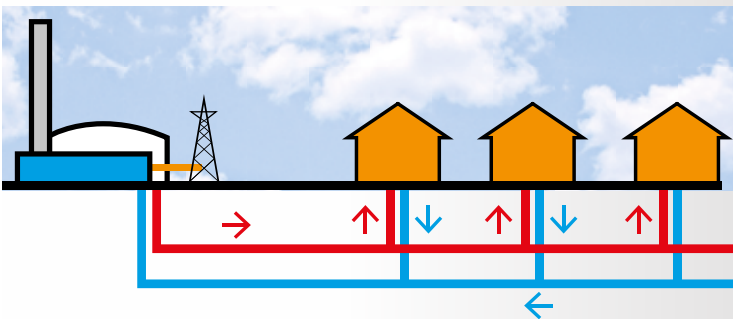
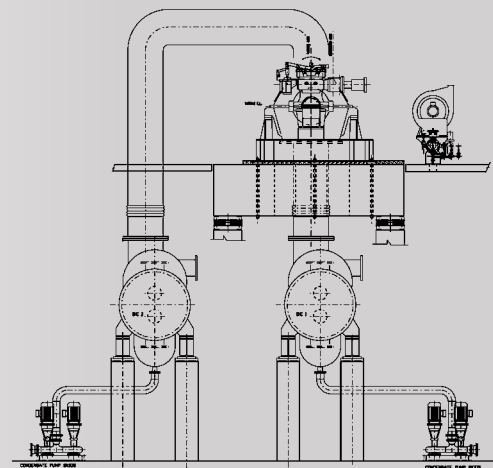
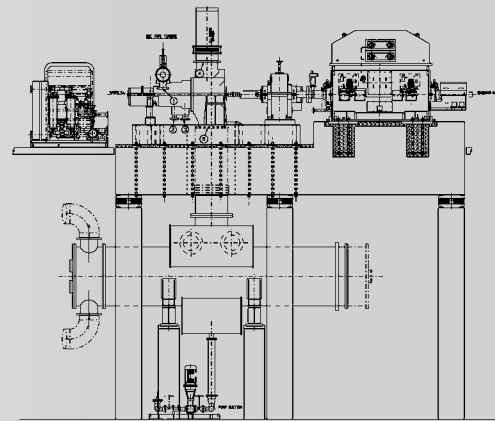

General Arrangement

Mezzanine Installation

— Suitable for both water and air cooled condensing systems. It allows very compact footprint and natural vertical drainage to condenser or recovery systems. This layout can also be used for backpressure turbines.

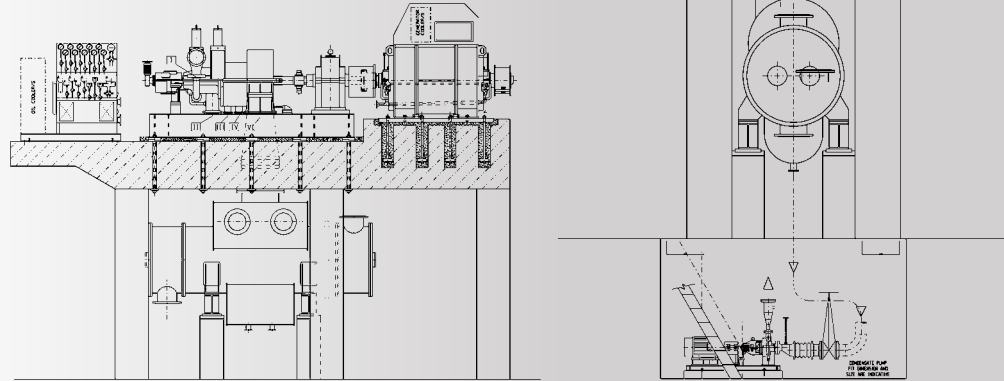

Ground Installation with Aside Condenser

— Suitable for water cooled condensing applications, it minimizes the civil works requirements.

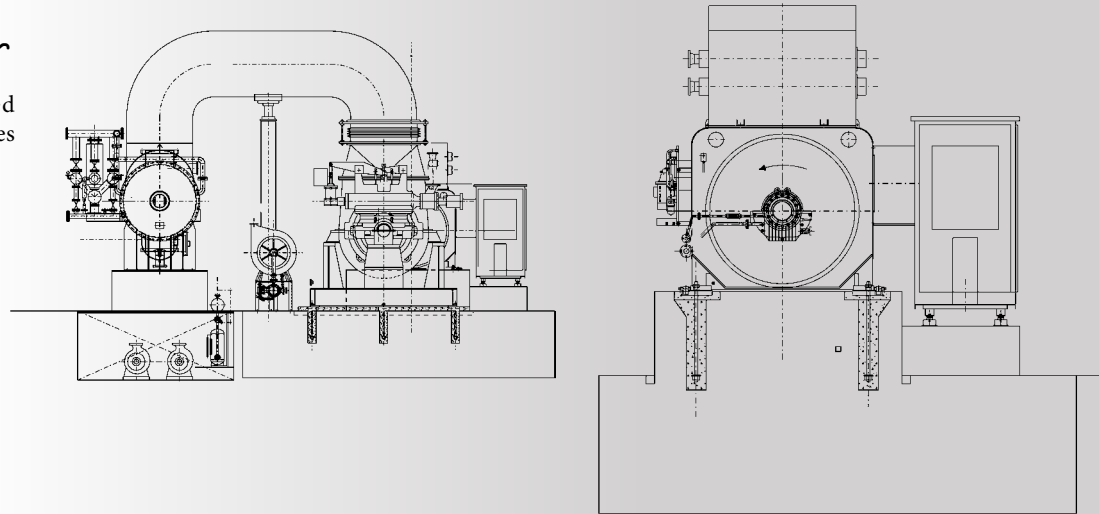

Ground Installation

— Suitable for backpressure and condensing turbine coupled with air cooled condenser. It minimizes the civil work requirements.

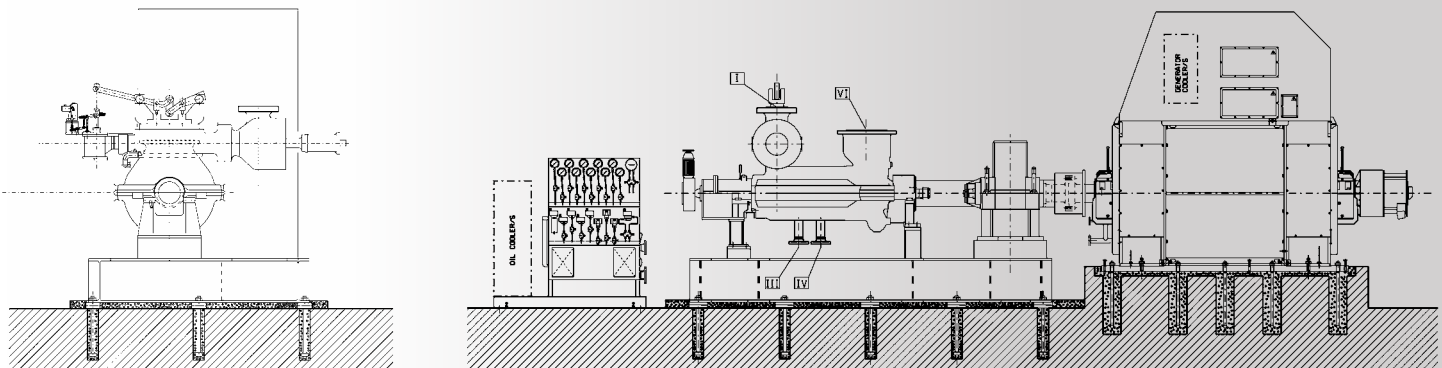

Marine Turbogenerators and Steam Ship Propulsion

Marine Turbogenerators

— Since the beginning of the twentieth century Fincantieri has applied its experience as naval shipbuilder and turbine manufacturer in the construction of both condensing and backpressure turbo-generators. The packages are very compact and easy to install. The turbine characteristics are similar to those of standard production.

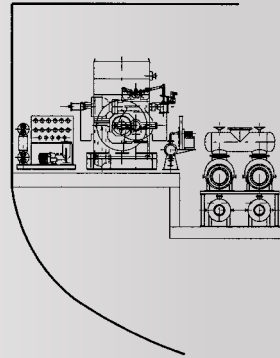
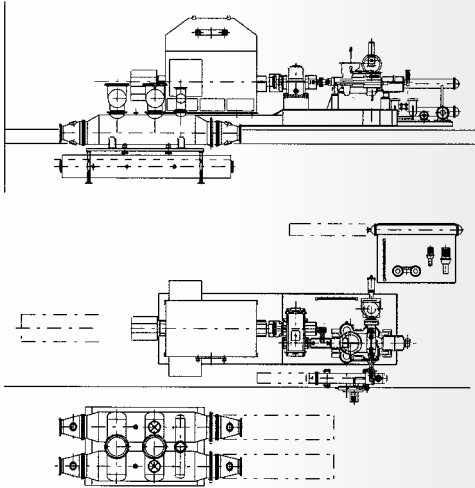

_ Typical Marine Application

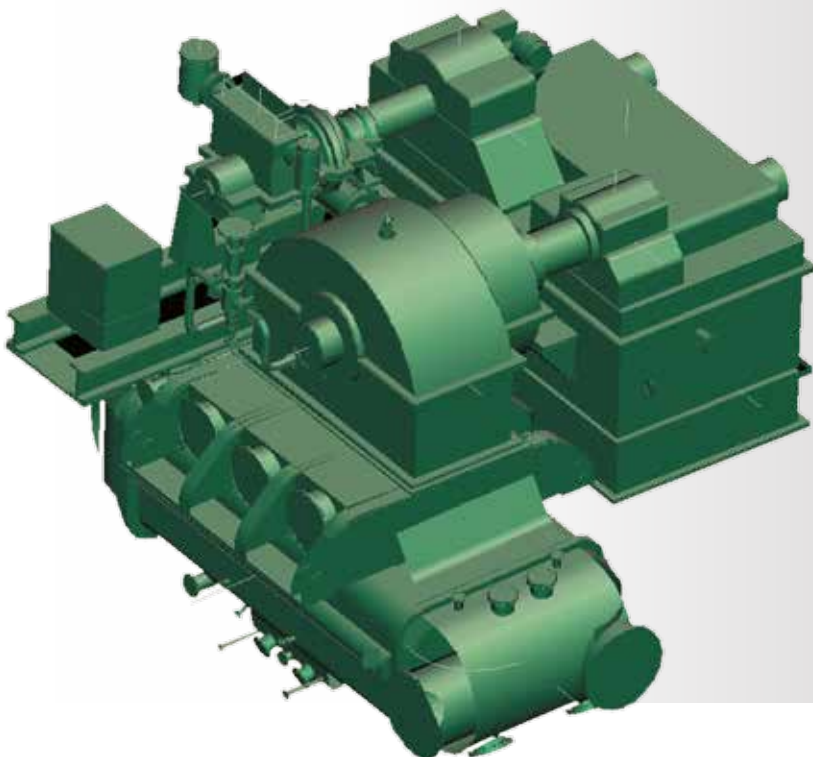

Steam Ship Propulsion

— Fincantieri has applied its experience as naval shipbuilder and turbine manufacturer to construct over 270 steam propulsion plants for both merchant (LNG carriers; coal fired bulk carriers) and naval vessels, in compliance with the highest standards.

"THR" and "TVR" Turbines



— The simple construction of Fincantieri THR and TVR steam turbines allows high reliability at a moderate cost. The turbine wheel - with a single stage or with a Curtis stage plus a second impulse stage - is assembled overhanging the pinion shaft, thus creating a very compact geared turbine unit. The steam exhaust - directed axially - allows an easy positioning on the floor.

— In any case the exhaust can be oriented either upwards or downwards according to customer's needs. The value of the exhaust pressure can vary from 0.1 bar to approximately 4 bar. These turbines can be used to generate electric energy and to drive pumps and compressors for both naval and industrial use.

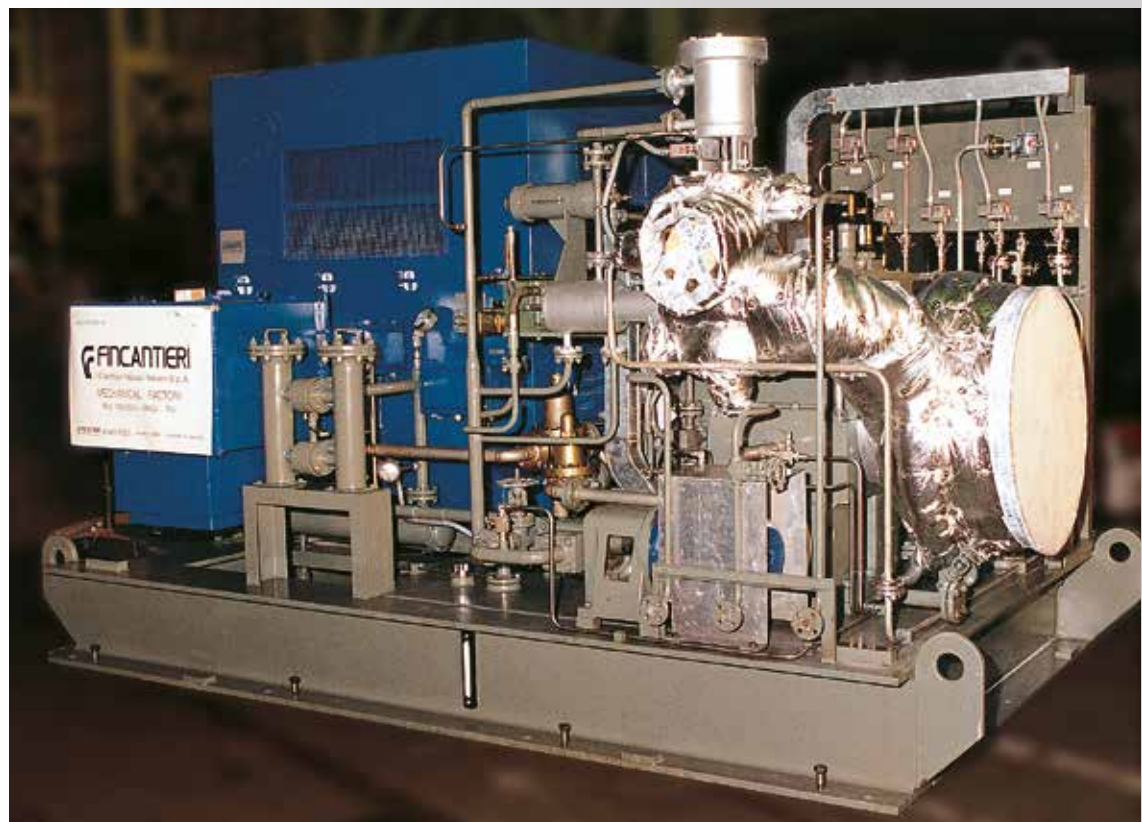

"F" Series

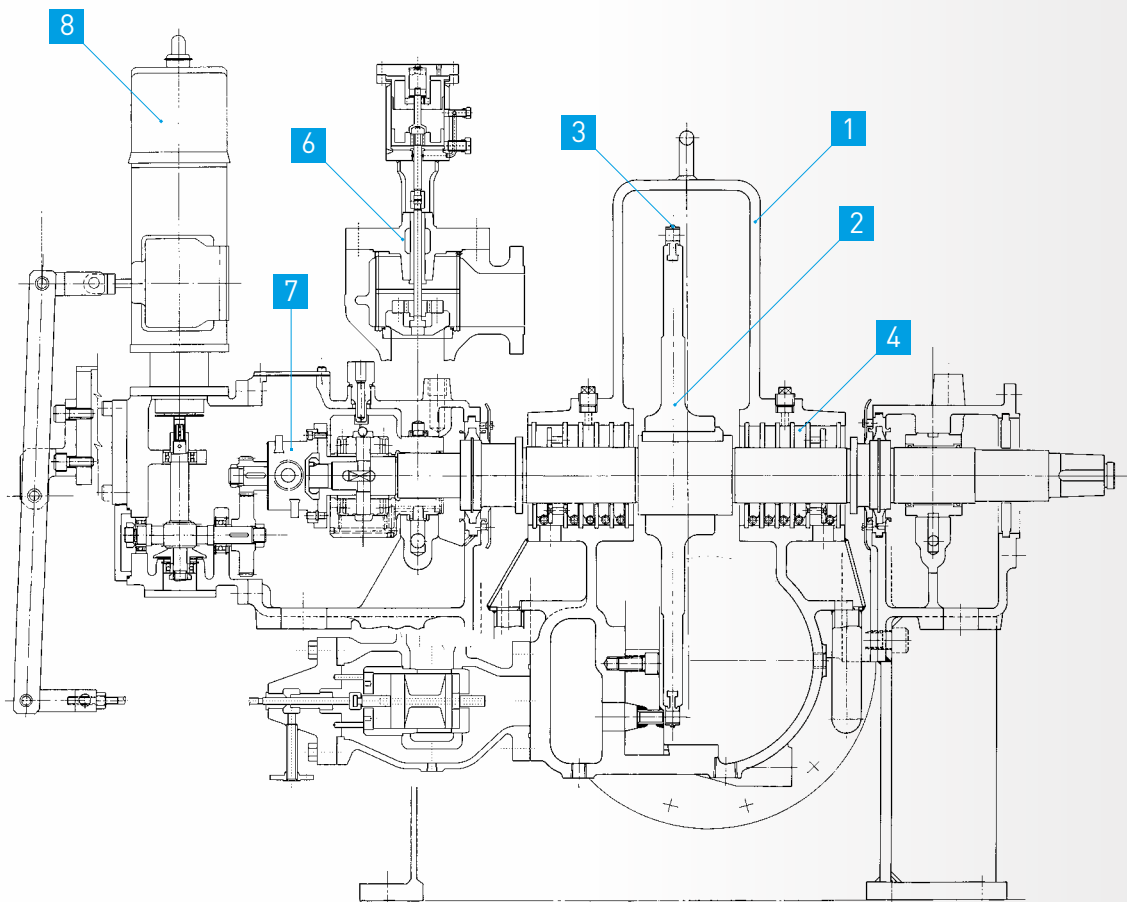
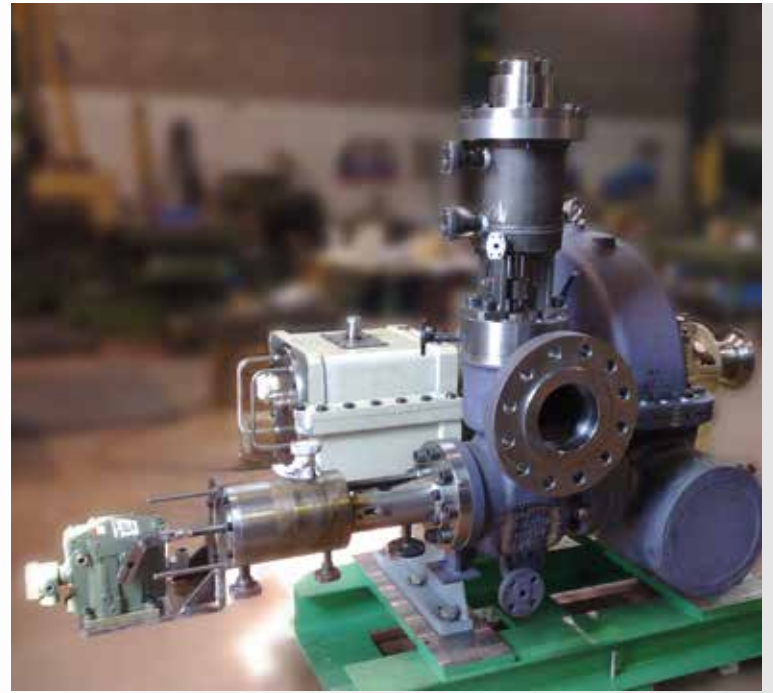

- 1 **TURBINE CASING** horizontally divided in two parts, both in steel casting metal to metal steam joint with the steam nozzle located in the lower half casing
- 2 **ROTOR DISK** machined from alloy steel solid forging, assembled with the rotor axis by key
- 3 **BLADING** impulse type, with one or more stages
- 4 **SEALING SYSTEM** metal packing labyrinth or carbon ring type
- 5 **CONTROL VALVE** hydraulic type, located and flanged on lower half casing

- 6 **TRIP VALVE** immediate reaction hydraulic type, located and flanged to control valve casing provided in option with hydraulic test device
- 7 **TRIP DEVICE** electronic / mechanical type for over speed and axial displacement
- 8 **SPEED GOVERNOR** mechanical or electronic type

■ Pump Drive

— For driving every type of **pumps**: feed pumps, circulating pumps, oil pumps, processing pumps for petrochemical plants, water pumps etc. For every duty for which is requested: reliability, easy use, low cost service.

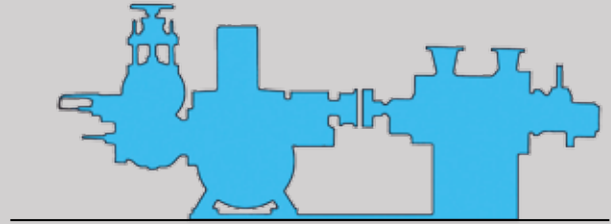

■ Fan - Compressor Drive

— For driving **fans**: boiler, flue gas extractor, centrifugal compressors, conditioning. For every continuous and heavy duty application.

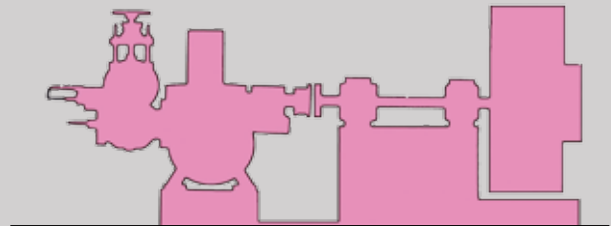

■ Generator Drive

— For driving **alternators**, for power generation for principal or stand by electric unit, for **driving machinery** in stand by in order to assure the continuous service also in case of black out.
For any requirement of easy and prompt intervention.

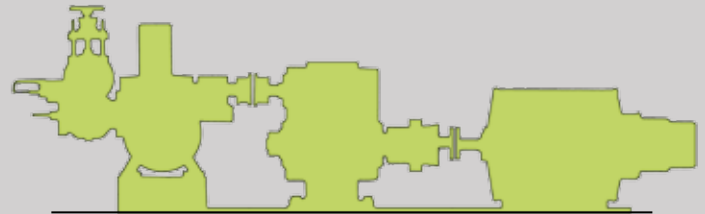

■ Geared Option (for any application)

— Available with **reduction or increasing gears**, in case of low driven machinery operating speed, still keeping steam turbine good efficiency.
Option with increasing gear for very high speed driven machines.

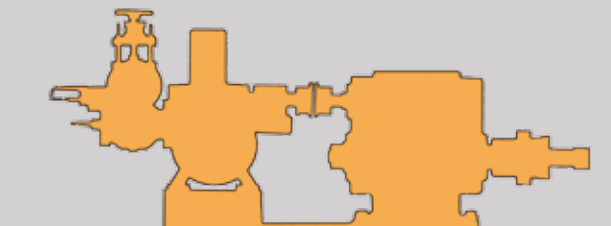

Control and Lube Oil System

— Fincantieri's basic philosophy - with respect to the control system - is to analyse the different final application of the steam turbines so as to be able to fully satisfy its clients with the best economical and technical solution suited to their specific needs.

A turbine control system has to fulfil different control functions to be integrated with the relevant processes.

Fincantieri uses an electronic control system with hydraulic actuators. This basic control system - designed in accordance with client requirements - can be managed by the local PLC and/or by the DCS of the plant.

Automatic start-up (hot start-up) is foreseen as standard. A full automatic turbine start-up (cold start-up) can be supplied, if required.

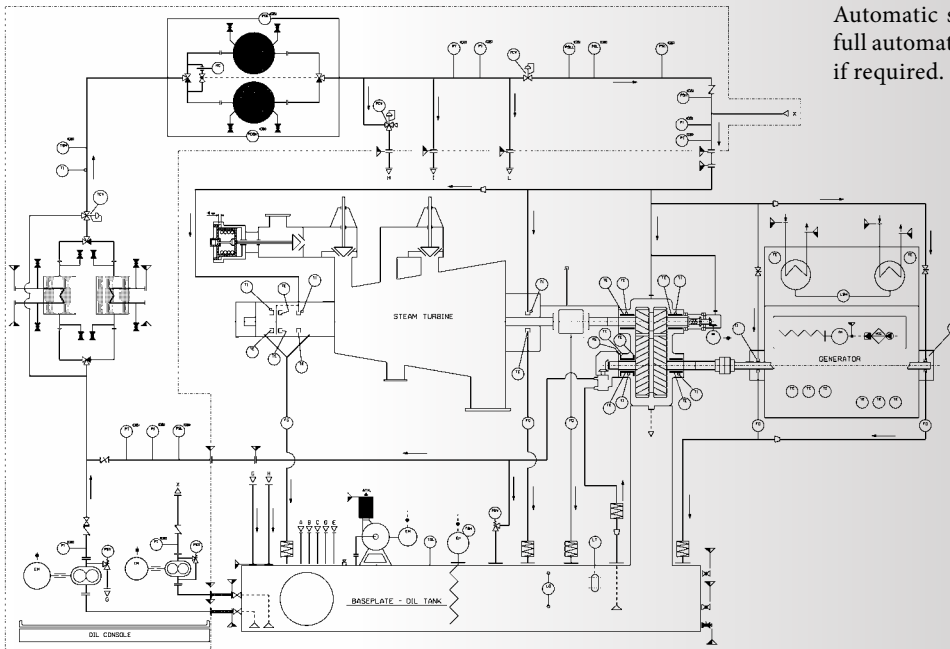

— Typical Lube Oil System

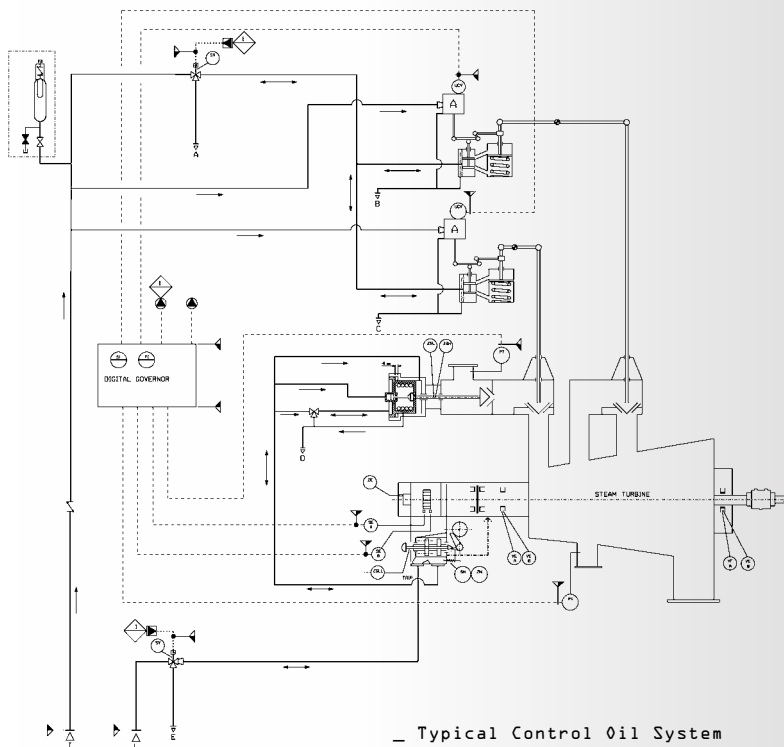

— Typical Control Oil System

Fincantieri uses two basic control procedures for steam turbines:

- Throttle control: regulation is obtained by controlling the steam pressure and consequently the steam flow, by a single valve.
- Nozzle control: regulation is obtained by controlling the inlet steam flow through the variation of the number of nozzles fed by the inlet steam. Each control valve feeds a group of nozzles.
- The throttle control system is used on single valve turbine types while nozzle control system is used on multi-valve types.

Control System

A Mechanical Drive Turbine/Electric Generation Turbine

The functions of:

- speed
- power
- inlet pressure or backpressure can be controlled

B Turbine with Single/Double Controlled Extraction

The functions of:

- speed
- power
- inlet pressure
- extraction pressures can be controlled

C Turbine with Non-Controlled Extraction

In case it is necessary a less precision on extraction pressure control at different operating power of the turbine, the non-controlled extraction (bleeding) is a cost saving solution, taking into consideration that the bleeding pressure is variable with the turbine load. Selective bleedings can be realized too.

Modular Construction

— In order to comply with market and client requirements Fincantieri has developed a modular system for the basic subassembly of its steam turbines. The machine is split into sub-components, such as control-valve nozzle chest; exhaust casings; intermediate sections; bearing housings; and more. The modular system allows to combine different components optimising the machine flexibility to the specific project requirements. The main module combinations are shown in the diagram both for backpressure (B) and condensing (C) turbine.

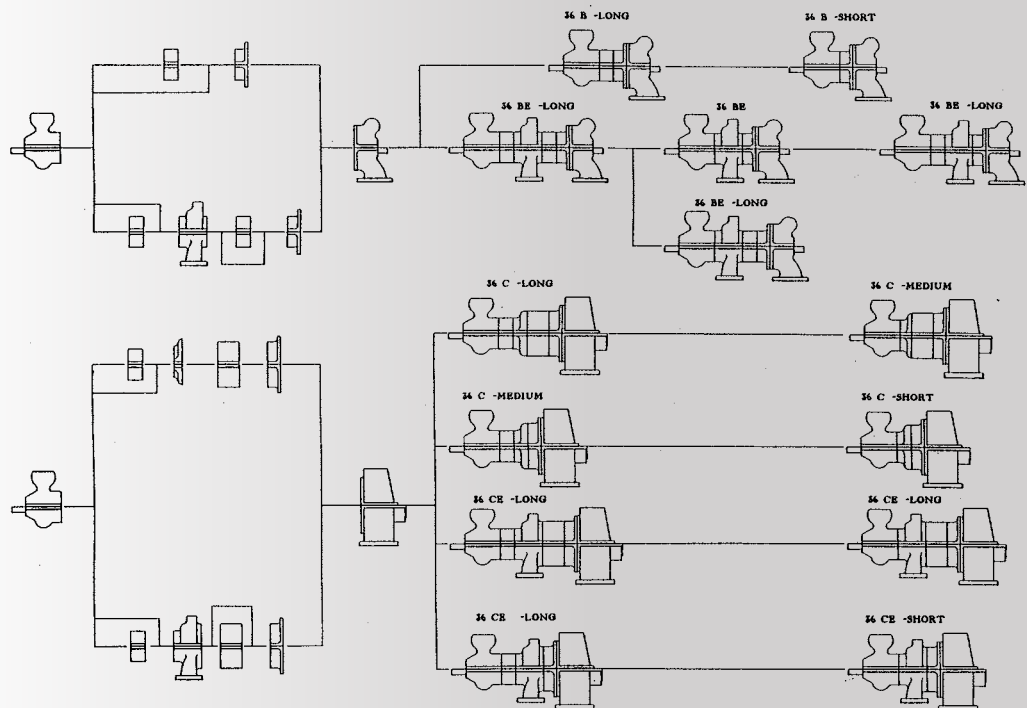

— Diagram of Turbine "Type 36" casing Modular Make-Up

After Sales Services

— Fincantieri provides installation and service activities for steam turbines. Installation activities include the assembly of the plant; the commissioning; the test running; and the training for operators. In addition the customer can plan and organise the maintenance and overhauling activities in co-ordination with our service department. Several skilled service teams - available around-the-clock - ensure professional assistance to the client by managing and solving any kind of problems and/or by performing the operations relevant to the machinery. Fincantieri provides planned inspection and preventive maintenance aimed to satisfy customer requirements.



After Sales Services which are Supplied:

- installation;
- commissioning;
- test runs;
- repairs;
- refurbishment;
- spare parts;
- consulting;
- maintenance;
- remote monitoring;
- inspection;
- supervision;
- training.

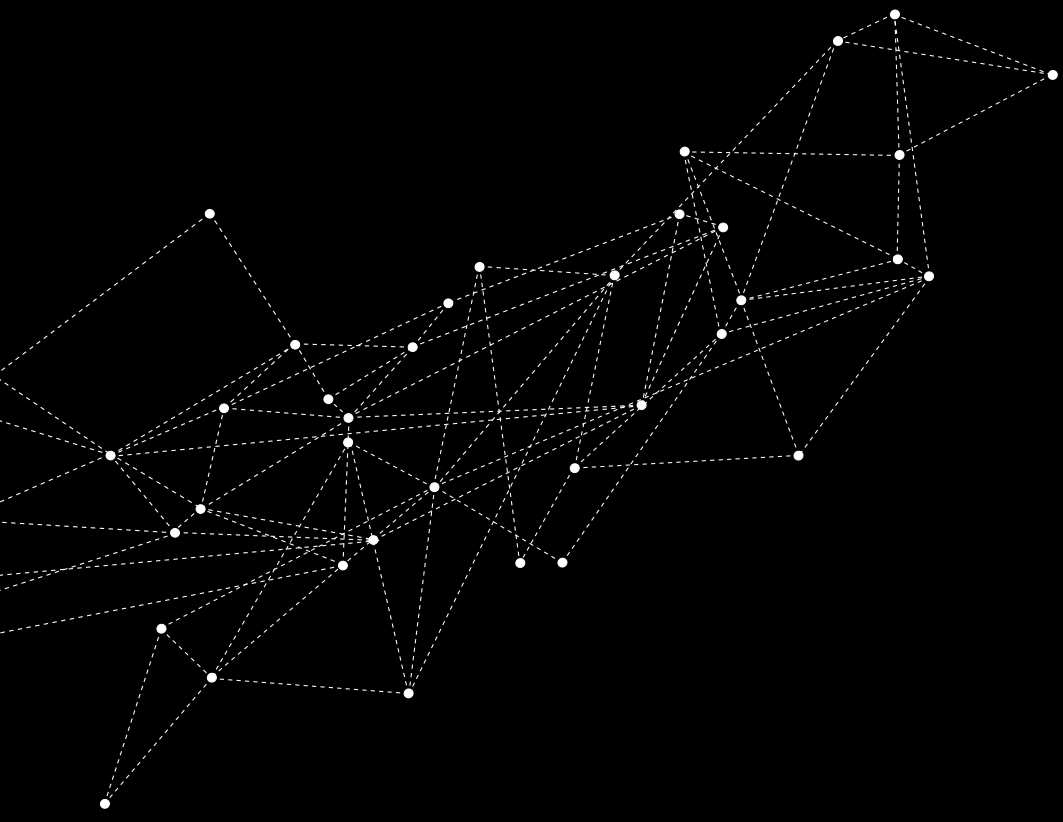

FINCANTIERI
The sea ahead



Head Office

Via Genova, 1 - 34121 Trieste (Italy)
ph. +39 040 3193111 - fax +39 040 3192305

Marine Systems and Components

Via Cipro, 11 - 16129 Genova (Italy)
ph. +39 010 59951 - fax +39 010 5995379

fincantieri.com

